

COOLANT HEATER

## Binar 5S Diesel / Gasoline



**Coolant heater Binar 5S** provides efficient pre-heating for engines, hydraulic systems, hot water tanks, and auxiliary heat for cab or cargo space. **Binar 5S** applications vary from any type of vehicles and heavy equipment to boats and motorhomes.

- With the coolant heater you can reduce cost of fuel in compliance with “no idling zone” regulations
- Coolant heater provides easy engine start at the temperature as low as  $-45^{\circ}\text{C}$
- Coolant heater covers all heating needs for your truck, bus, recreational vehicle, or boat
- Each heater comes with installation kit
- 2-year warranty on parts and labor

### Coolant heater Binar 5S Diesel / Gasoline

- Operates on diesel or gas and 12V power independently from engine
- Generates up to 17,000 btu/h (5.0 kW)
- Extremely low fuel and power consumption
- Provides instant coolant heating up to  $95^{\circ}\text{C}$
- Fully automated temperature control and programmable start
- Compact design and “plug-and-play” installation
- Self-diagnostic system
- Optional wireless remote control

# Binar 5S - Diesel Binar 5S - Gasoline

## TECHNICAL SPECIFICATIONS



Standard kit includes:

- Coolant heater Binar 5S
- Mounting bracket
- Circulation pump with set of rubber hoses and fittings
- Metering fuel pump with fuel lines and wire harness
- Control panel:
  - automatic temperature control
  - programmable start
- Wire harness assembly
- Exhaust flexible pipe, stainless
- Combustion air intake silencer
- Set of fasteners and hardware

Binar 5S -Diesel	
RATED VOLTAGE	12V
FUEL	DIESEL
HEATING CAPACITY	17,000 btu/h (5.0 kW)
COOLANT	ANTIFREEZE
FUEL CONSUMPTION	0.16 gal/h (0.62 L/h)
EL. POWER CONSUMPTION	6.0 A
WEIGHT	8.8 lb (4.0 kg)
DIMENSIONS (L x W x H)	8.7 x 3.5 x 5.3 in. (220 x 90 x 136 mm)

Binar 5S -Gasoline	
RATED VOLTAGE	12V
FUEL	GASOLINE (PETROLEUM)
HEATING CAPACITY	17,000 btu/h (5.0 kW)
COOLANT	ANTIFREEZE
FUEL CONSUMPTION	0.18 gal/h (0.7 L/h)
EL. POWER CONSUMPTION	6.0 A
WEIGHT	8.8 lb (4.0 kg)
DIMENSIONS (L x W x H)	8.7 x 3.5 x 5.3 in. (220 x 90 x 136 mm)

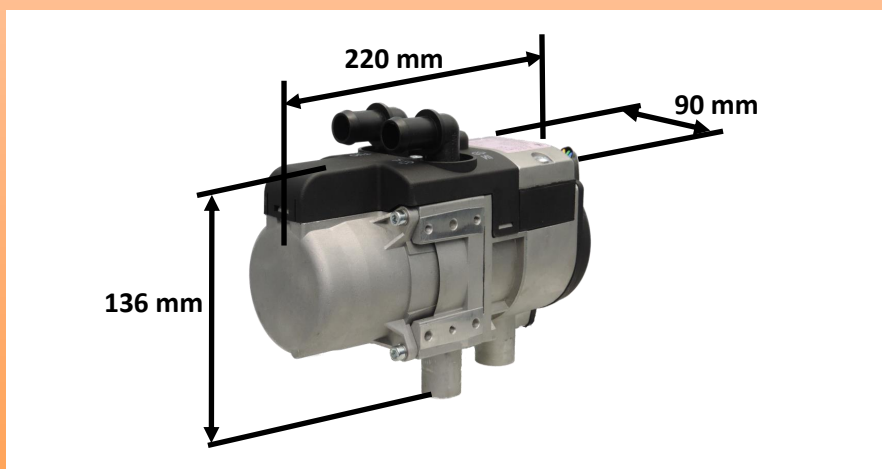

**PLANAR MARINE and TRUCK AIR HEATERS Ltd.**

109-18635 52 Ave.

Surrey, BC V3S 8E5

Phone: 1 (604) 719-4663

Toll free: 1 (844) 259-8591

[www.PLANARHEATERS.COM](http://www.PLANARHEATERS.COM)

Contact your local dealer: