

FORCED AIR DIESEL HEATER

PLANAR 4DM2



Forced air diesel heater PLANAR 4DM2 is designed for providing instant heat to the interior of any type of the vehicles, boats, and motorhomes.

- With the air heater PLANAR 4DM2 you can reduce cost of fuel in compliancy with “no idling zone” regulations
- The air heater PLANAR 4DM2 is a great way to extend your boating season: for boats 25-35 ft. long
- Efficient performance and quiet operation
- Each heater comes with installation kit
- 2-year warranty on parts and labor

Forced air heater PLANAR 4DM2

- Operates on diesel and 12V or 24V power independently from engine
- Consumes 1 liter of fuel for up to 4 hours of operation
- Generates 11,000 BTU/h with a strong air flow
- Fully automated temperature control
- Self-diagnostic system
- Compact design and “plug-and-play” installation

PLANAR 4DM2

TECHNICAL SPECIFICATIONS

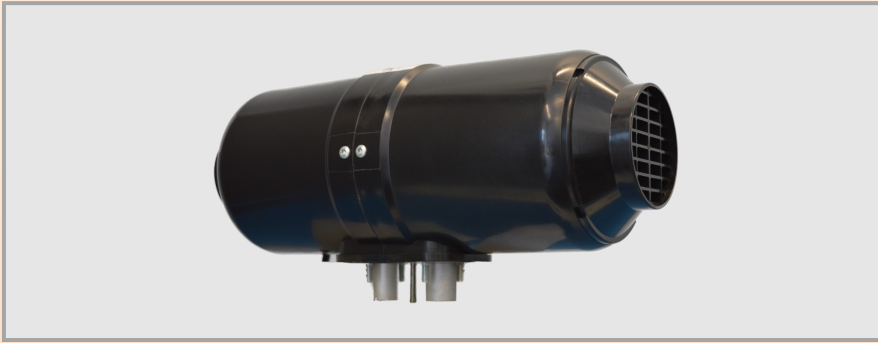

PLANAR 4DM2	
RATED VOLTAGE	12V or 24V
FUEL	DIESEL
HEATING CAPACITY	3,400 - 10,500 btu/h (1.0 - 3.0 kW)
AIR FLOW RATE	41 - 71 ft ³ /m (70 - 120 m ³ /h)
FUEL CONSUMPTION	0.03 - 0.10 gal/h (0.12 - 0.37 l/h)
EL. POWER CONSUMPTION	0.8 - 3.8 A (10.0 - 46.0 W)
WEIGHT	15.5 lbs (7.0 kg)
DIMENSIONS (L x W x H)	15.4 x 5.8 x 6.3 in. (392 x 148 x 160 mm)

Standard kit includes:

- Air heater PLANAR 4DM2-12 (or -24)
- Metering fuel pump with fuel lines and wire harness
- Fuel tank, 7L.
- Control panel:
 - automatic temperature control
 - various settings
- Wire harness assembly
- Exhaust flexible pipe, stainless
- Exhaust muffler
- Combustion air intake silencer
- Set of fasteners and hardware
- Instruction manual

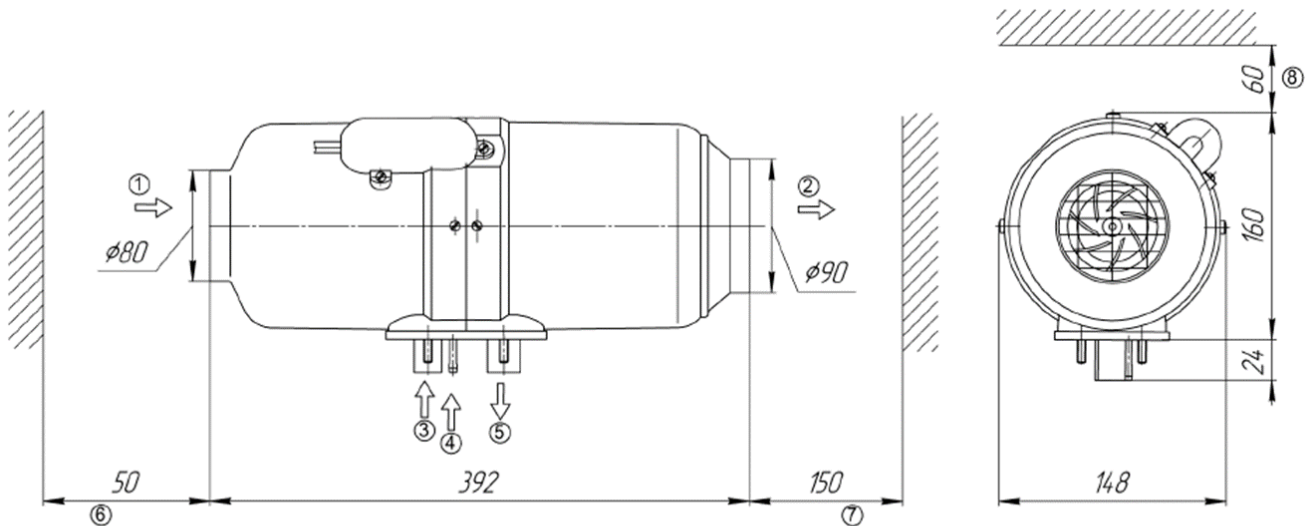

1. Heating air intake
2. Heating air outlet
3. Combustion air intake
4. Fuel supply

5. Exhaust gas outlet
6. Required gap at heating air intake, min. 50mm
7. Required gap at heating air outlet, min. 150mm
8. Required gap for technical maintenance, min. 60mm

PLANAR MARINE and TRUCK AIR HEATERS Ltd.

109-18635 52 Ave.
Surrey, BC V3S 8E5
Phone: 1 (604) 372-3222
Toll free: 1 (844) 259-8591

www.PLANARHEATERS.COM

Contact your local dealer: