

FORCED AIR DIESEL HEATER

## PLANAR 9D



**Forced air diesel heater PLANAR 9D** is designed for providing instant heat to the interior of any type of the vehicles, buses, boats, and motorhomes.

- With the air heater PLANAR 9D you can reduce cost of fuel in compliancy with “no idling zone” regulations
- The air heater PLANAR 9D is a great way to extend your boating season: for boats 50 – 75 ft. long
- Efficient performance and quiet operation
- Each heater comes with installation kit
- 2-year warranty on parts and labor

### **Forced air diesel heater PLANAR 9D**

- Operates on diesel and 12V or 24V power independently from engine
- Consumes 1 liter of fuel for up to 2 hours of operation
- Generates 27,300 BTU/h with a strong air flow
- Fully automated temperature control available
- Self-diagnostic system
- Compact design and “plug-and-play” installation

# PLANAR 9D

## TECHNICAL SPECIFICATIONS



Standard kit includes:

- Air heater PLANAR 9D-12 (or -24)
- Metering fuel pump with fuel lines and wire harness
- Control panel
- Fuel tank, 7 L.
- Fuel pickup stand pipe
- Wire harness assembly
- Exhaust flexible pipe, stainless
- Set of fasteners and hardware
- Instruction manual

PLANAR 9D	
RATED VOLTAGE	12V or 24V
FUEL	DIESEL
HEATING CAPACITY	10,900 - 27,300 btu/h (3.2 - 8.0 kW)
AIR FLOW RATE	41 - 170 cfm (70 - 290 m <sup>3</sup> /h)
FUEL CONSUMPTION	0.11 - 0.26 gal/h (0.42 - 1.0 l/h)
EL. POWER CONSUMPTION	12.0 - 215.0 W (1.0 - 17.9A / 0.5 - 7.5A)
WEIGHT	37.6 lbs (18.0 kg)
DIMENSIONS (L x W x H)	25.6 x 8.3 x 11.0 in. (650 x 212 x 281 mm)

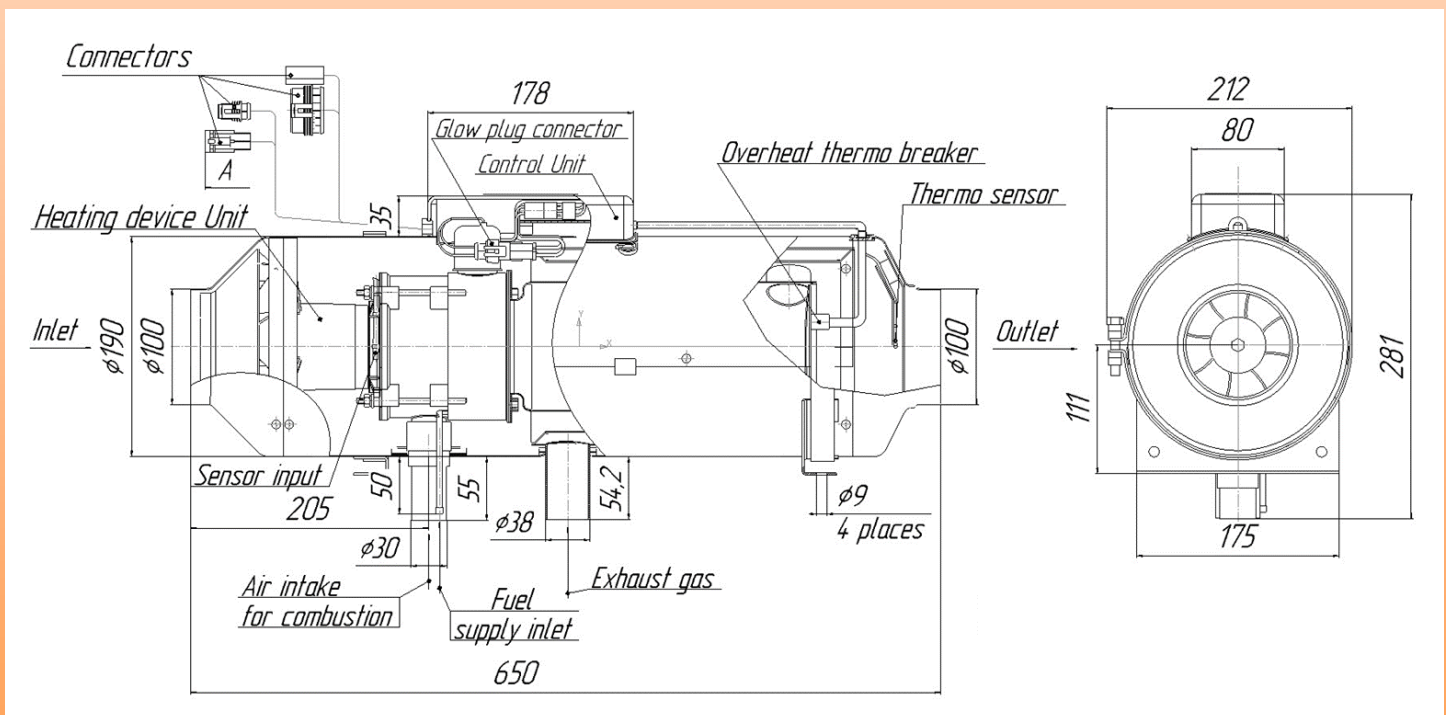

**PLANAR MARINE and TRUCK**  
**AIR HEATERS Ltd.**

109-18635 52 Ave.  
 Surrey, BC V3S 8E5  
 Phone: 1 (604) 372-3222  
 Toll free: 1 (844) 259-8591  
[www.PLANARHEATERS.COM](http://www.PLANARHEATERS.COM)

Contact your local dealer: