



**ULTIMATRON
FRANCE**

**5 YEARS
WARRANTY**

Technical sheet

ULTIMATRON LiFePO4 Smart BMS Underseat of Camping Vehicle
12.8V 280Ah with Heater

Compared with traditional batteries, our lithium iron phosphate batteries (LiFePO4) have many advantages:

- 5-year manufacturer's warranty
- The safest technology, without risk of fire or explosion
- Long service life
- Constantly improving storage capacity
- High stability even under extreme loads
- No memory effect, no need for full charge and discharge cycles
- High performance even under extreme conditions
- Deep and regular discharge and charging efficiency
- Small size and light weight



Integrated Battery Management System (BMS)

To allow the control and the charge of the different elements of an accumulator battery and to protect it against overcharging, overvoltages and overheating.



It can be connected in parallel.
Series connection is not allowed.

Integrated Bluetooth 4.0 monitoring



You have all important battery data always on your smartphone or tablet. The application displays the data in real time.

N. American Distributor:
Planar Distribution Ltd.
Unit 106 18663 52 Ave, Surrey BC Canada

Ph: 1 (604) 372-3222
Toll free: 1 (844) 259-8591
E: ultimatron@planarheaters.com
W: planarheaters.com/ultimatron-batteries/



**ULTIMATRON
FRANCE**

TECHNICAL SHEET

ULM SMART BMS SERIES 12.8V

ULTIMATRON LiFePO4 Smart BMS 12.8V 280Ah with Heater

ELECTRICAL PERFORMANCE

Nominal Voltage	12.8 V
Nominal Capacity	280 Ah
Capacity @ 50A	336 min
Energy	3584 Wh
Resistance	≤15 mΩ @ 50% SOC
Self Discharge	<3% / Month
Cells	Prismatic cells 3.2V/280Ah

DIMENSION

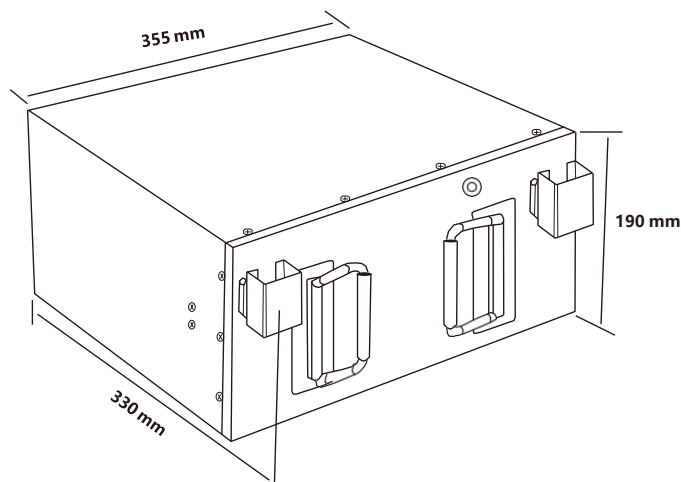

Dimensions L355*W330*H190 mm (L14.0*W13.0*H7.5 in.)

CHARGE PERFORMANCE

Recommended Charge Current	50 A
Maximum Charge Current	40 A
Recommended Charge Voltage	14.6 V
Charge Cut-Off Voltage	14.88 (1000mS)
Reconnect Voltage	14 V
Balancing Voltage	>13.6 V

DISCHARGE PERFORMANCE

Continuous Discharge Current	50 A
Maximum continuous Discharge Current	200 A
Peak Discharge Cut-Off Current	220 A (15 ~25 S)- 620A(320 ~1280m S)
Recommended Low Voltage Disconnect	10 V
Discharge Cut-Off Voltage	9.2V (3000ms)
Reconnect Voltage	>10.4 V
Short Circuit Protection	1000-2000A ±400A (200 ~ 800 μs)

MECHANICAL PERFORMANCE

Weight	31 kg. (68 lb.)
Terminal Type	M8
Terminal Torque	80 ~ 100 in-lbs (9 ~ 11 N-m)
Bluetooth	Bluetooth 4.0 with smartphone App
Case Material	Metal
Enclosure Protection	IP65

TEMPERATURE PERFORMANCE

Discharge Temperature	-20 ~ 65 °C (-4 ~ 149 °F)
Charge Temperature	-20 ~ 55 °C (-4 ~ 131 °F)
Storage Temperature	-5 ~ 35 °C (23 ~ 95 °F)
High Temperature Cut-Off	65 °C (149 °F)
Reconnect Temperature	55 °C (131 °F)

COMPLIANCE

Certifications	CE UN38.3 UL1642 & IEC62133
Shipping Classification	UN 3480, CLASS 9

ULTIMATRON FRANCE

Add: 60 Avenue de l'industrie 34820 Teyran

info@ultimatron-franceifr

Tel:+33(0)9 50 42 76 17

MARQUE FRANÇAISE

